

Model:FS-207Z

Class 800

Screwed Ends



**Features:**

- Design Manufacture : API 602
- Screw end dimensions : ANSI B1.20.1/NPT
- Socket Welding dimensions : ASME B16.11
- Material according to ANSI / ASTM
- Test Standard: API 598
- Bolted bonnet and outside screw and yoke
- Material: Class 800, Trim 8
- Application: Steam,Hot Water,Oil, Gas
- Max.Working Pressure: 800psi (55bar)
- Max Working Temperature: 425 C

**Material**

NO.	Part Name	Material
1	Body	A105
2	Seat Ring	A276 420+STL
3	Disc	A276 420
4	Stem	A276 410
5	Gasket	304+Graphite
6	Bonnet	A105
7	Bolt	A193 B7
8	Packing	Firber
9	Packing	Graphite
10	Gland	A276 410
11	Glang Flange	A105
12	Pin	35
13	Drop Bolt	A193-B7
14	Hexagon Nut	A194 2H
15	Stem Nut	A276 410
16	Lubricating Gasket	25
17	Hangwheel	A197
18	Name Plate	LY12
19	Tightening Nut	A194 2H

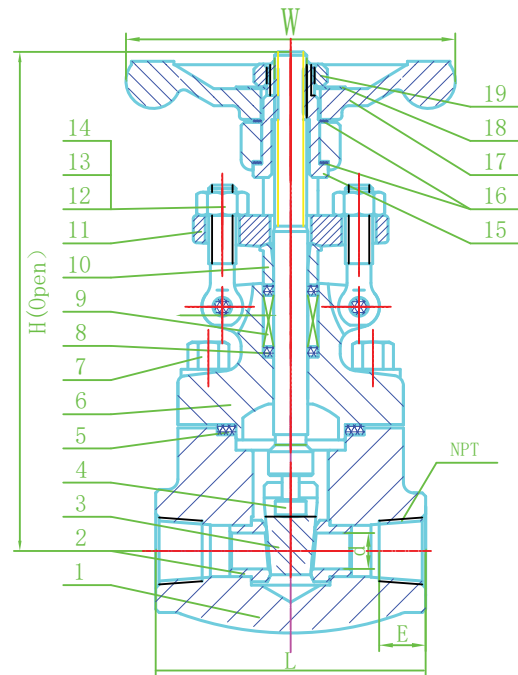

**Dimension**

Unit: mm

Size	1/2"	3/4"	1"	1 1/4"	1 1/2"	2"
L	79	92	111	120	120	140
H	140	148	188	240	240	285
E	13.6	13.9	17.3	18.4	18.4	19.3